

THE AI EVOLUTION

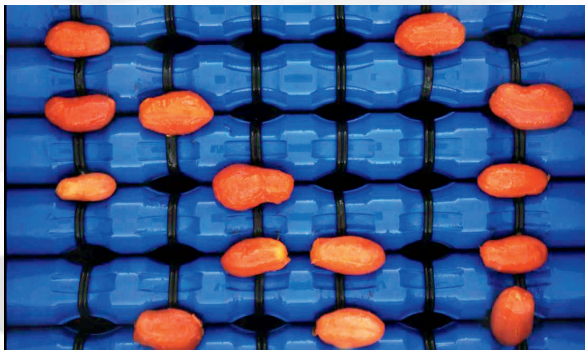

**From "massive" to "punctual" vision
for unprecedented efficiency**



OPPORTUNITY is an optical food sorter which exploits artificial intelligence (Deep Learning) for 360-degree product quality control.

Thanks to the roller belt (spin belt) that allows products to rotate and matrix cameras to capture entire frames of the rolling product, the software enables increased product quality, completely replacing manual sorting.

OPPORTUNITY is based on the principle of self-learning and can be adapted to the selection of different types of products. With its compact design and ability to communicate with other machines, Opportunity can be easily placed within processing lines to contribute to complete production automation.

OPPORTUNITY is capable of performing a real-time "identikit" of each product, on each side. This enables to identify even the slightest defect and presence of necrotic in any part of the tomato.

The great advantage of artificial intelligence, is that the machine is "trained" with the acquisition of many images and easily adapts to the growing needs of quality control.

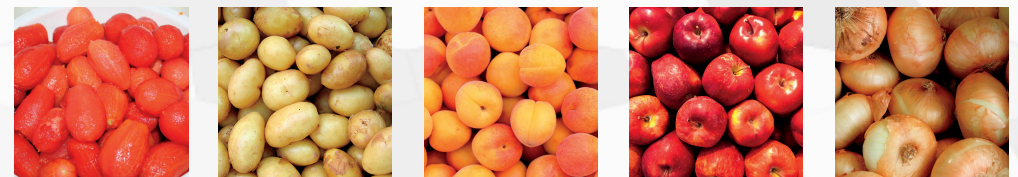

Benefits



High production capacity



Low maintenance

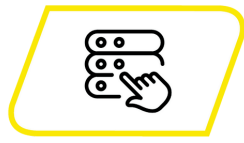

Constant selection over time



Automatic capture of images



Real time detection



User friendly software

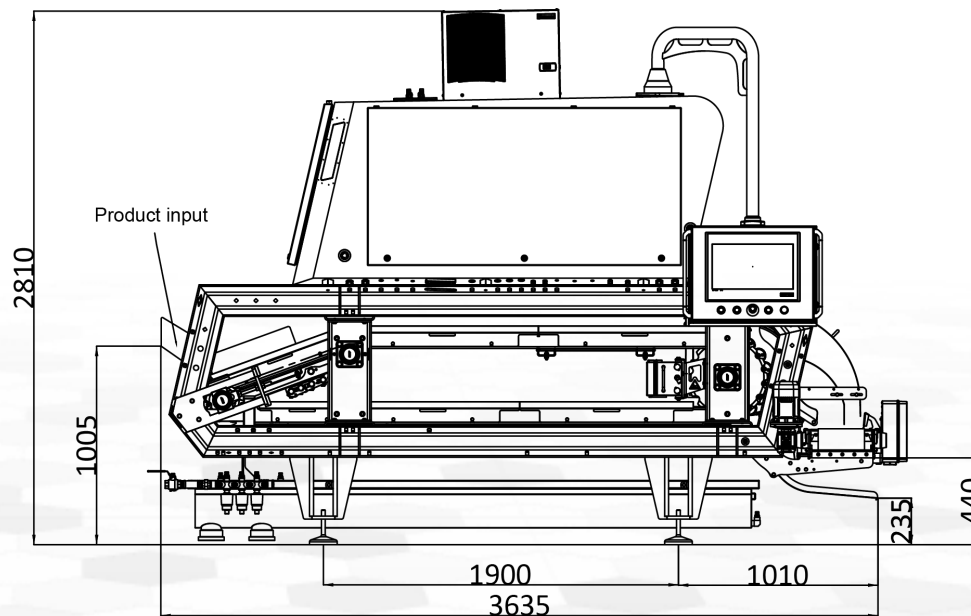

Technical data

Model	OY-600	OY-1200	OY-1800
Capacity	Up to 10t/h	Up to 20t/h	Up to 30t/h
Machine length	3.600 mm		
Inspection belt width	600 mm	1.200 mm	1.800 mm
Inspection belt speed	20-45 m/min		
Pixel size	0,3x0,3 mm		
Number of ejection valves	6	12	18

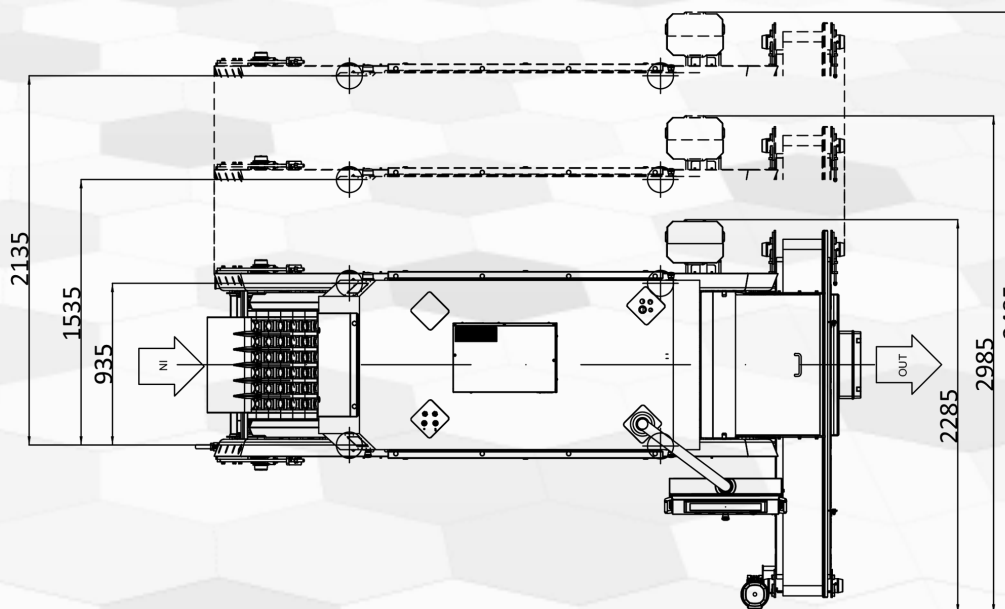

Ver 03|2023